

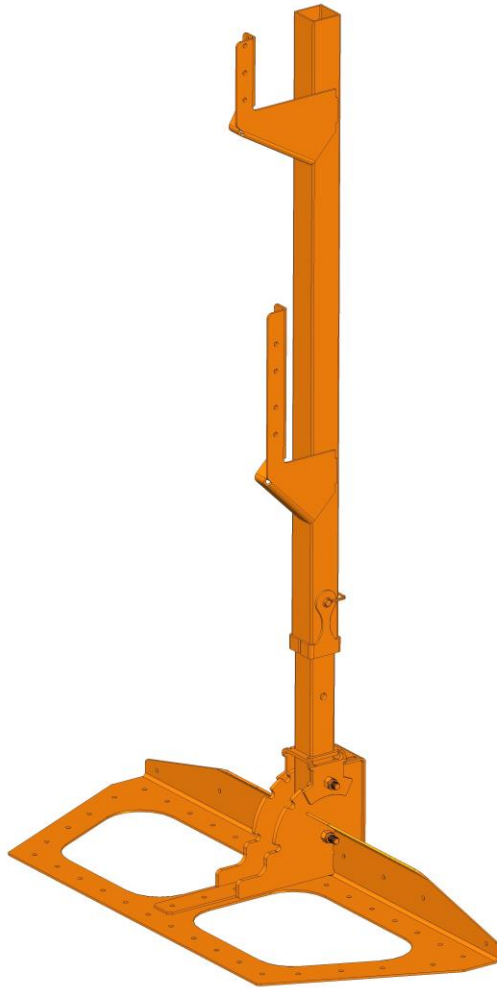

RAPIDGUARD

USERS GUIDE



Les Fabrications TJD www.tjd.ca

© All rights reserved. No copy or reproduction of this manual, in all or in part, may be made without the explicit agreement of Les Fabrications TJD .

All rights reserved © 2007 Les Fabrications TJD

Users guide

Although calculations and tests have shown that the adjustable uprights installed according to this manual, meets the ASP Construction's code, the user remains the solely responsible for the guardrails installation. **Therefore, *Les Fabrications TJD Inc.* may not now or at any time be held responsible for any damage, injuries, loss of life or any other type of loss connected with the use of the adjustable guardrails.** When installing, using and dismantling, the user is responsible for seeing that all regional work safety standards and laws, in effect where guardrails are to be used, are followed.

Important: A regular inspection as well as repairs and replacement of defective components are the users' responsibility.

A. Preparation

- a. Ensure that all bases and uprights used are in good condition and are in no way defective or broken. Any part having a defect must be repaired or replaced before using.
- b. Refer *to figures 1 through 4* to establish an installation arrangement best suited to how the guardrails will be used.
- c. Ensure it will be possible to place the uprights so that they are spaced at the maximum value indicated in the following table. (Reference only)

Maximum length between posts		
Spruce section (no.1 grade)	(Humid wood)	(Dry wood)
Top and middle rail		
38 mm x 89 mm (1 ½ in by 3 ½ in)	1.5 m (5 ft.)	1.8 m (6 ft.)
38 mm x 140 mm (1 ½ in by 5 5/8 in)	2.6 m (8 ft. - 8 in)	3.0 m (10 ft)
Toeboard		
25 mm x 100 mm (1 in by 4 in)	N/A	2.4 m (8 ft.)
30 mm x 150 mm (1 in par 6 in)	N/A	3.0 m (10 ft.)

- d. For any installation on sloping roofs, it is necessary to plan for additional guardrails to ensure that there is a maximum distance of 1.8 meters (6 feet) between workers and the nearest guardrails (See figure 2). However, the roof's slope must never exceed a 5:12 ratio. (22 degrees).

2. Attaching the bases

- a. Depending on the chosen installation arrangement, refer *to details E through H* to find out which base holes positions to use in order to ensure that the bases are effectively anchored.
- b. Ensure that all principal fastening holes are positioned over structural elements such as joists, roof trusses, supporting frames, etc.
- c. Fasten the base solidly using 2 ½-long, ¼ inch-diameter lag bolts (or any other type of fastener which ensures an equal or superior anchoring) in all the base holes referenced in section 2.a.
- d. In order to ensure good contact with the base and avoid breaking it, each lag bolt needs a flat washer with at least 20 millimeters outside diameter.
- e. Repeat steps a) through d) on every base.

3. Adjusting the uprights

- a. Install the upright onto the base using the hardware provided. Position the top rail so that once in place, it is between the workers and the upright. *(See figure 1 through 4 as well as illustrations of related details)*
- b. To position the upright as needed, pull it up along the tube's axis to disengage the attaching mechanism. Pivot the upright to the desired angle and release the tube. Ensure that the locking mechanism is engaged. Make sure that the mechanism of restraint is perfectly engaged and that nothing interferes between the bolt, the shoe and the indented plates. The contact areas (surfaces) must be respected to assure an adequate use. *(See figure 5)*
- c. Repeat steps a) and b) for all uprights.

4. Attaching guardrails

- A. Attach guardrails to the uprights using at least 2, #8 wood screws (1 ½ in. long) per upright.
- B. Ensure that the top rail is between 1 and 1.2 meters *(Height A of figure 6)* above footing where workers are to stand.

- C. Attach middle rail which is at least 75 millimeters wide at mid-height ([Height B of figure 6](#)).
- D. Solidly attach the bottom rail (toeboard) to the base of the uprights. (*See figure 1 through 4 as well as illustrations of related details*)
- E. Repeat steps a) through e) for all guardrails.

5. Inspection

Once installation is finished, ensure that:

- a. It can resist a concentrated horizontal force of 900 newtons (200 lbf) applied to any point of the top rail. ([See figure 6](#))
- b. It can resist a concentrated vertical force of 450 newtons (100 lbf) applied to any point of the top rail. ([See figure 6](#))
- c. It includes all essential elements; bottom, middle and top guard rails. ([See figure 6](#))
- d. It respects any safety standards in effect in the region in which it is being used and this applies for the entire duration of its use.

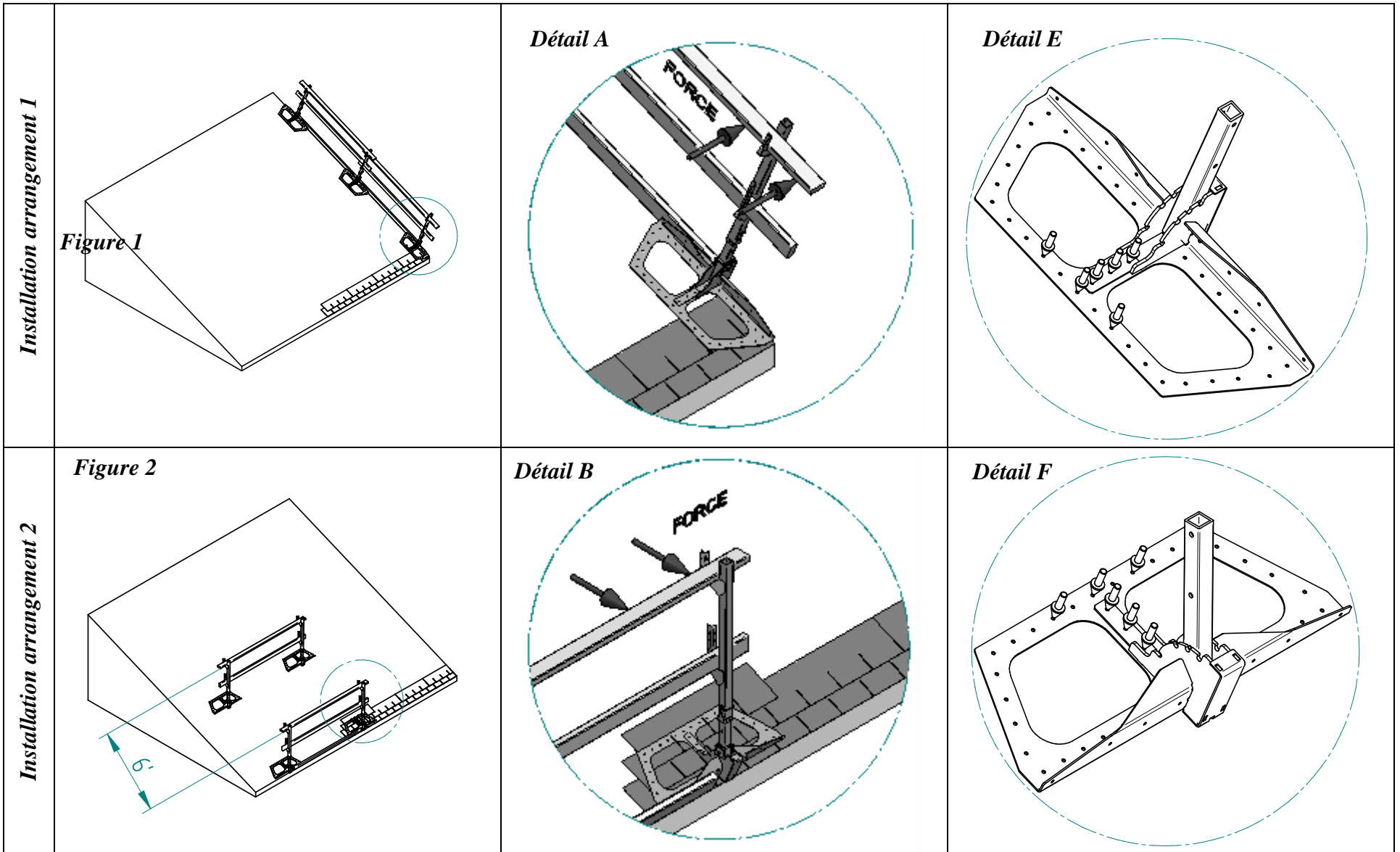

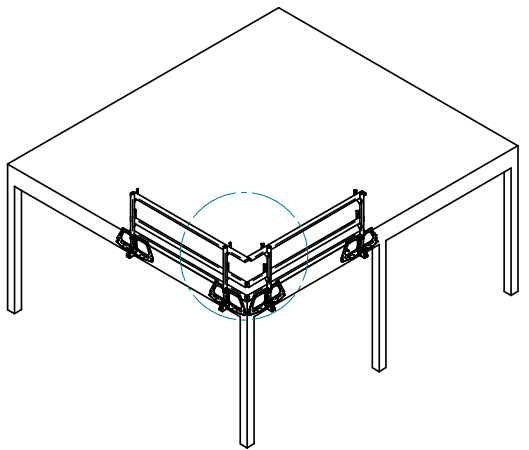
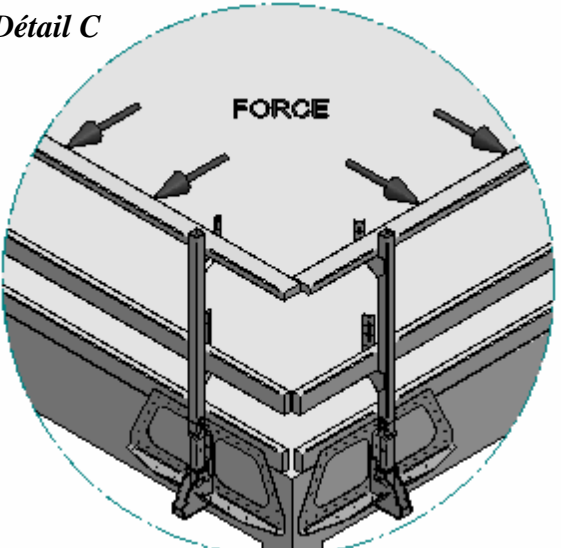
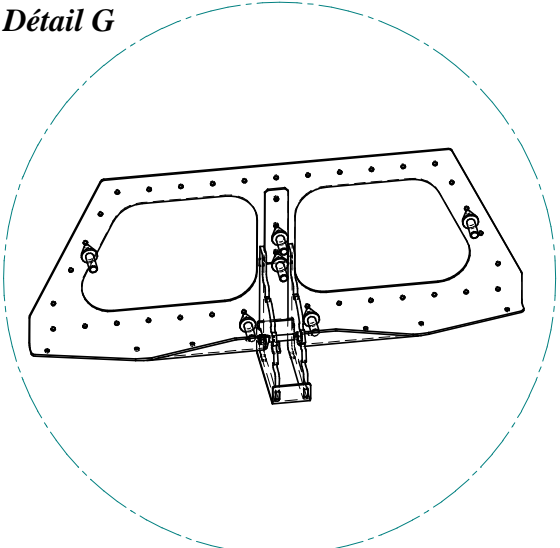
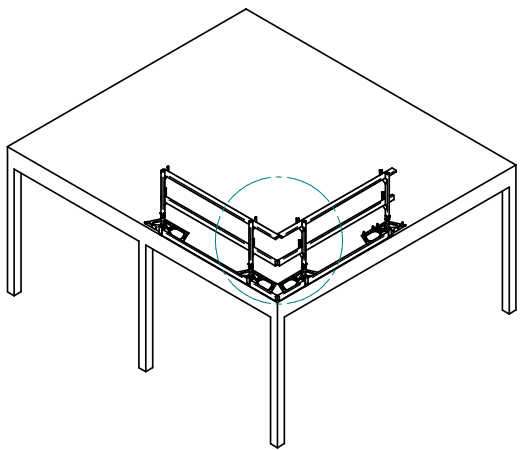
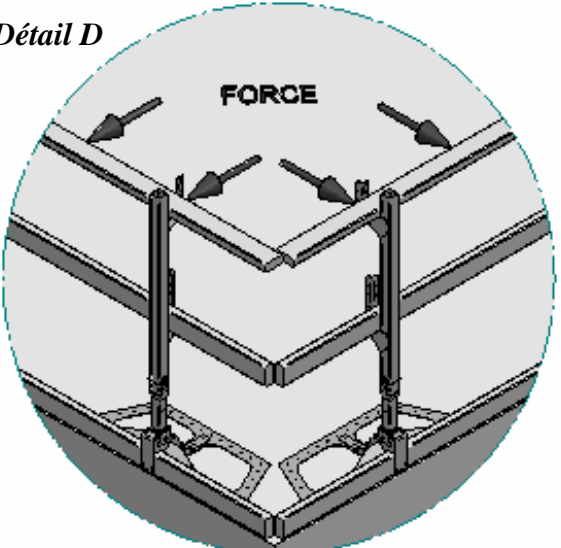
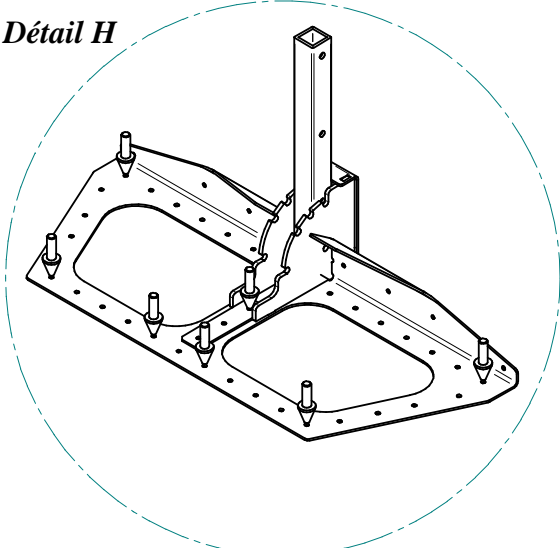
<p><i>Installation arrangement 3</i></p>	<p><i>Figure 3</i></p> 	<p><i>Détail C</i></p> 	<p><i>Détail G</i></p> 
<p><i>Installation arrangement 4</i></p>	<p><i>Figure 4</i></p> 	<p><i>Détail D</i></p> 	<p><i>Détail H</i></p> 

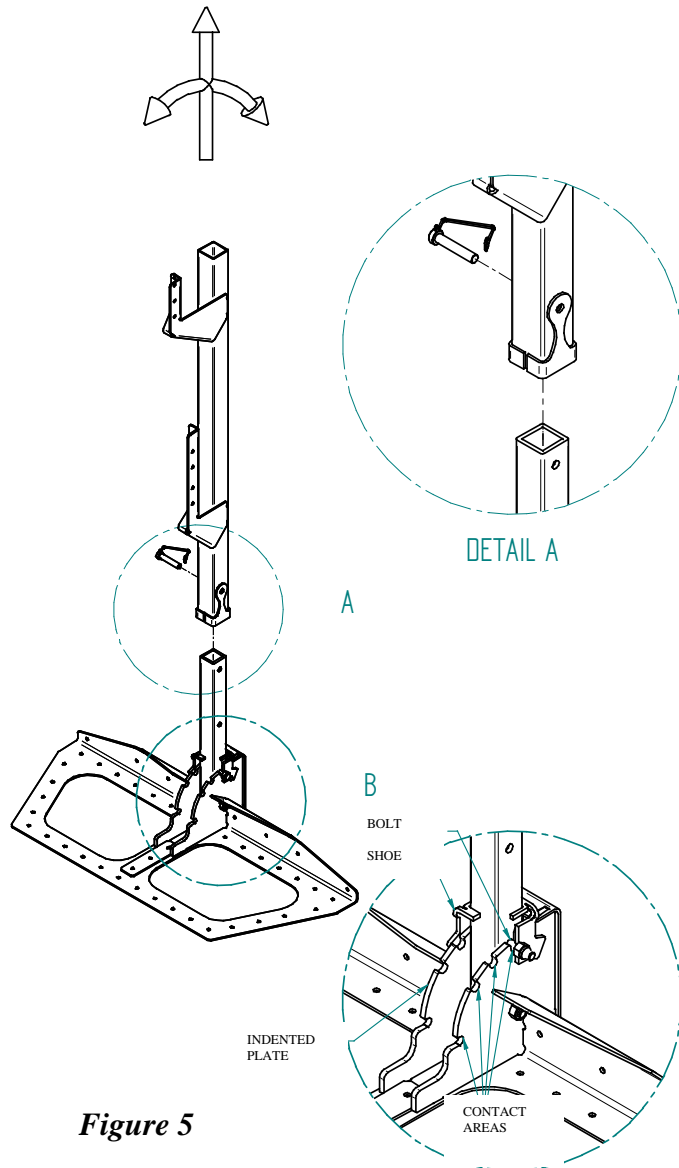

Figure 5

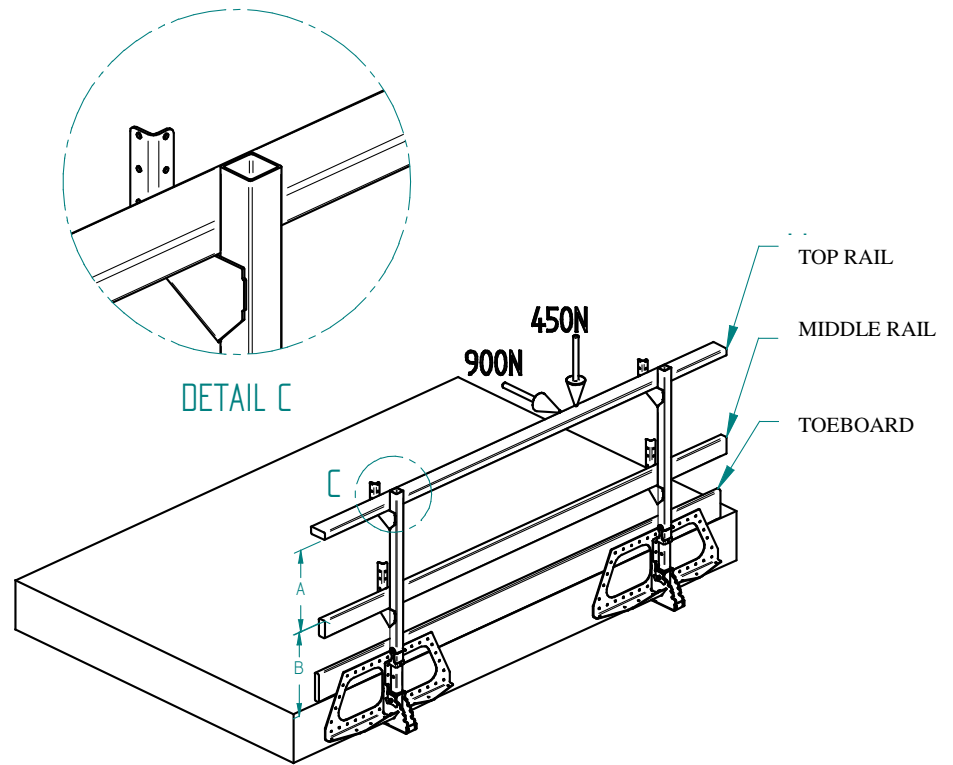

Figure 6